

850nm Fiber Optic Receiver Module in Dual-in-Line Package



OPF2416, OPF2416T, OPF2416TC

Technical Data

Features

- 850 nm wavelength
- Link distance up to 2 km
- Data rates up to 155 Mbps
- Wide operating temperature range
- Optimized for use with 62.5/125 μ m and 50/125 μ m Multimode Fiber
- ST[®] Receptacle
- Wave Solderable Dual-in-Line Package

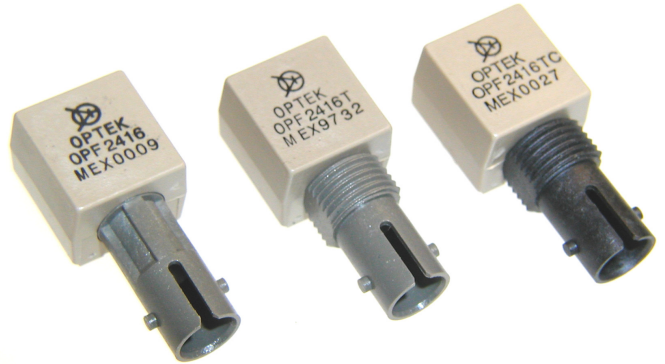

Description

The OPF0400 series is a cost effective solution for 850 nm fiber optic link designs. The transmitter and receiver pair are designed for use with multimode optical fiber with either 50/125 μ m or 62.5/125 μ m diameters. This fiber optic pair is housed in a space saving, auto-insertable package that is compatible with most wave solder processes.

Receiver

OPF2416 is a low cost solution for high speed, fiber optic communications designs. The internal lensing of this receiver's design allows optimal response from fiber sizes of 100 μ m and below.

The receiver is comprised of a high speed, low noise, photodiode coupled to a transimpedance amplifier (TIA). The photodiode/TIA combination produces an output voltage that is proportional in the input light amplitude. This hybrid approach solves many of the problems of high speed data link designs by placing the photodiode close to the TIA. The amplification of the TIA makes the output much less susceptible to EMI.

The output of the OPF2416 is an analog, low impedance, emitter follower voltage source. Subsequent circuitry can be utilized to convert the analog voltage to ECL/TTL for digital data rates up to 155 Mbps.

The OPF2416 is available with either standard or threaded panel mount ST[®] receptacles. The threaded version is also available in conductive plastic. Refer to the part number guide for more details.

ST[®] is a registered trademark of OFS Fitel USA.

Absolute Maximum Ratings

Storage Temperature Range	-55 to +85 °C
Operating Temperature Range	-40 to +85 °C
Lead Soldering Temperature	260 °C for 10 Seconds
Supply Voltage Range	-0.5 to 6.0 V
Output Current	25mA
Output Pin Voltage	-0.5 V

Recommended AC coupled receiver circuit

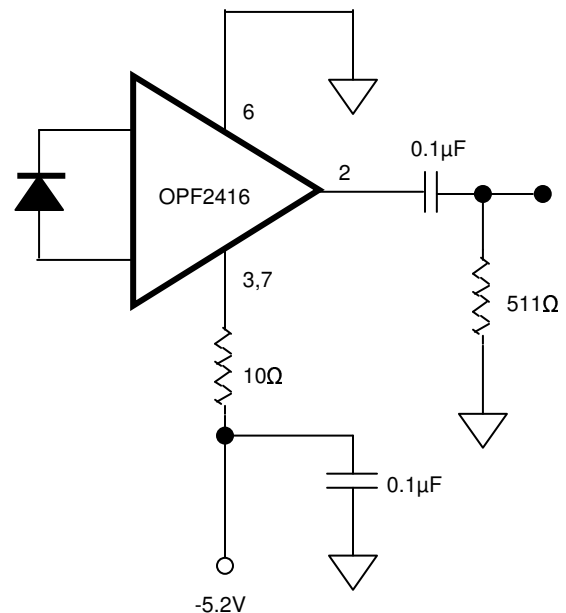

May 2003
Issue 1.0

OPF0400 Series Technical Data



Part Number Guide

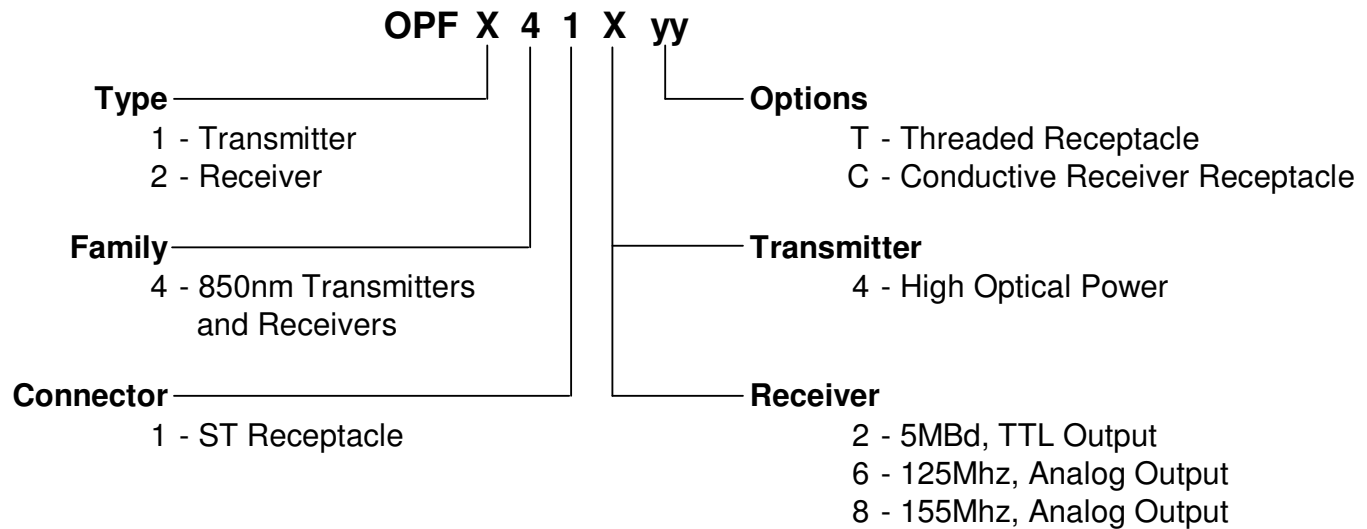

Link Selection Guide

Data Rate (MBd)	Distance (m)	Transmitter	Receiver	Fiber Size (µm)
5	1500	OPF1414	OPF2412	200 HCS
5	2000	OPF1414	OPF2412	62.5/125
20	2500	OPF1414	OPF2416	62.5/125
30	2000	OPF1414	OPF2416	62.5/125
50	1500	OPF1414	OPF2416	62.5/125
125	500	OPF1414	OPF2416	62.5/125
155	300	OPF1414	OPF2418	62.5/125

Distances listed in this guide are for reference only. A link budget should be completed for the specific application to determine actual distance.

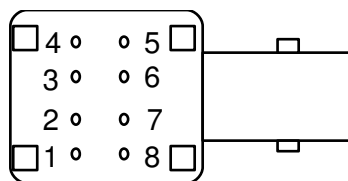

Bottom View

Pin	OPF2416 OPF2416T OPF2416TC
1	N.C.
2	Signal
3	V _{EE}
4	N.C.
5	N.C.
6	V _{CC}
7	V _{EE}
8	N.C.

Optek reserves the right to make changes at any time, without notice, in order to improve design and provide the best product possible. May 2003 Issue 1.0

OPF2416 Technical Data



OPF2416 Receiver Electrical/Optical and Dynamic Characteristics

-5.45V ≤ V_{CC} ≤ -4.75, Operating Temperature Range -40 to 85°C unless otherwise noted

SYMBOL	PARAMETER	MIN	TYP	MAX	UNITS	TEST CONDITION
R _P	Responsivity	5.3	7.0	9.6	mV/μW	λ _P =850 nm, 50 MHz T _A =25°C
		4.5		11.5	mV/μW	λ _P =850 nm, 50 MHz
V _{NO}	RMS Output Noise Voltage		0.40	0.59	mV	75 MHz Bandwidth P _R = 0 μW
				0.7	mV	Unfiltered Bandwidth P _R = 0 μW
P _N	RMS Equivalent Optical Noise Input Power		-43.0	-41.4	dBm	f =100 MHz P _R = 0 μW
			0.050	0.065	μW	
P _R	Peak Received Optical Power			-7.6	dBm	T _A =25°C
				175	μW	
				-8.2	dBm	
				150	μW	
V _O	Output Voltage	-4.2	-3.1	-2.4	V	P _R = 0 μW
I _{CC}	Supply Current		9	15	mA	R _L = ∞
BW	Bandwidth		125		MHz	-3 dB electrical
t _r , t _f	Rise and Fall Time		3.3	6.3	ns	f =50 MHz P _R = -10 dBm, peak
PWD	Pulse Width Distortion		0.4	2.5	ns	P _R = -10 dBm, peak
PSRR	Power Supply Rejection Ratio		20		dB	10MHz

OPF2416 Series Technical Data



ST Receptacle

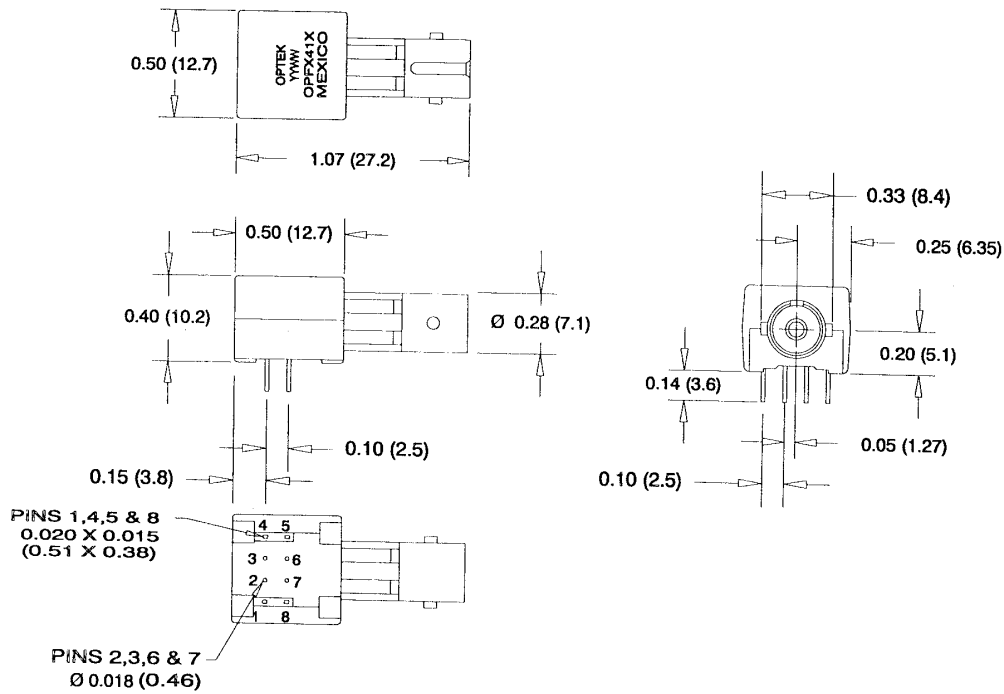

Treaded ST Receptacle ("T" and "TC" suffix)

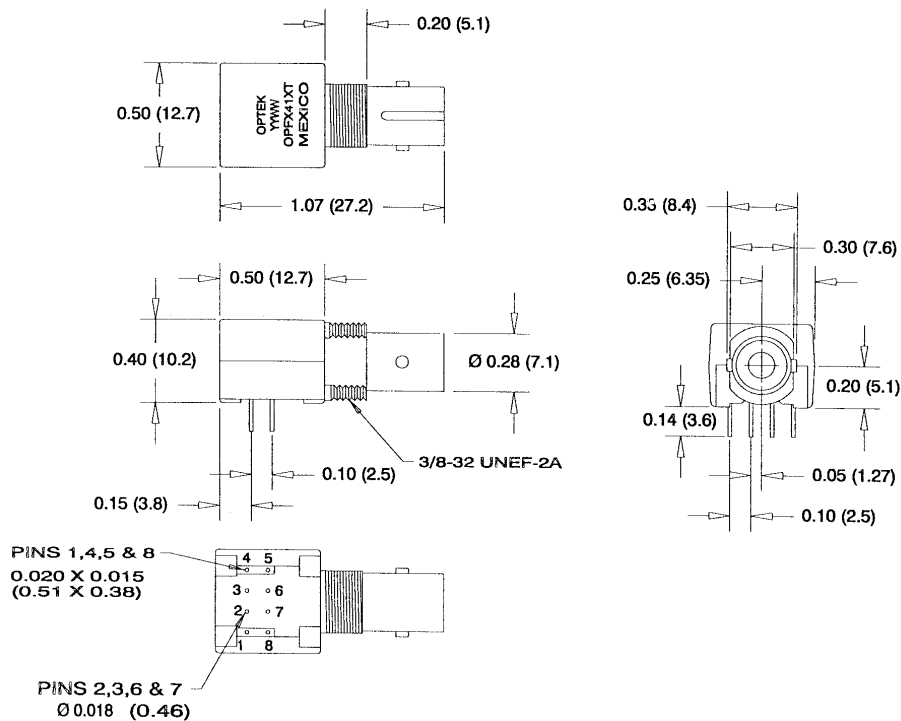

February 2003
OPF2416, Issue 1

Optek reserves the right to make changes at any time, without notice, in order to improve design and provide the best product possible.

May 2003
Issue 1.0